

---

SP-151C-1J64  
SP-181C-1J64  
SP-181C-2J64  
SP-211C-1J64  
SP-150R-1J64  
SP-170R-1J64

**Industrial Fanless Panel PC, w/ Intel® Elkhart  
Lake Celeron J6412 Processor**

# **User's Manual**

**Version 1.1**

---

## Revision History

Version	Date	Description
1.0	2024.01	Initial release
1.1	2025.08	Add SP-181C-2J64 SKU and related information

<b>Revision History .....</b>	<b>ii</b>
<b>Contents .....</b>	<b>i</b>
<b>Preface.....</b>	<b>iii</b>
Copyright Notice .....	iii
Declaration of Conformity .....	iii
CE.....	iii
FCC Class A .....	iii
RoHS .....	iv
SVHC / REACH .....	iv
Important Safety Instructions .....	v
Warning.....	vi
Lithium Battery Replacement.....	vi
Technical Support .....	vi
Warranty.....	vii
<b>Chapter 1 - Introduction.....</b>	<b>1</b>
1.1. The Computer .....	2
1.2. About this Manual .....	2
1.3. Specifications.....	3
1.4. Inside the Package .....	6
<b>Chapter 2 - Getting Started.....</b>	<b>7</b>
2.1. Dimensions .....	8
2.2. Tour the Computer .....	10
2.2.1. Front View.....	10
2.2.2. Bottom I/O View .....	10
2.2.3. I/O Definition .....	11
<b>Chapter 3 - Engine of the Computer.....</b>	<b>15</b>
3.1. Board Layout.....	16
3.2. Connectors & Jumpers .....	19
<b>Chapter 4 - Installation and Maintenance.....</b>	<b>23</b>
4.1. Disassembling and Assembling the Computer .....	24
4.1.1. Disassembling the Computer.....	24
4.1.2. Assembling the Computer.....	25
4.2. Install M.2 2242 SSD, M.2 2230 & Memory Stick Module .....	25
4.3. Install the Wi-Fi Module .....	27
4.4. Mounting Method .....	27
4.4.1. Panel Mounting.....	27
4.4.2. VESA Mounting.....	27
<b>Chapter 5 - BIOS.....</b>	<b>29</b>
5.1. Main - Sets system Time & Date.....	32
5.2. Advanced .....	33

5.2.1. COM Mode Setting .....	34
5.2.2. Wake System with Fixed time.....	35
5.3. BIOS Chipset Menu .....	36
5.3.1. BIOS Chipset Menu .....	37
5.4. Security .....	38
5.5. Boot.....	39
5.6. Save & Exit .....	40

## Copyright Notice

All Rights Reserved.

The information in this document is subject to change without prior notice in order to improve the reliability, design and function. It does not represent a commitment on the part of the manufacturer.

Under no circumstances will the manufacturer be liable for any direct, indirect, special, incidental, or consequential damages arising from the use or inability to use the product or documentation, even if advised of the possibility of such damages.

This document contains proprietary information protected by copyright. All rights are reserved. No part of this document may be reproduced by any mechanical, electronic, or other means in any form without prior written permission of the manufacturer.

## Declaration of Conformity

### CE

The CE symbol on your product indicates that it is in compliance with the directives of the European Union (EU). A Certificate of Compliance is available by contacting Technical Support.

This product has passed the CE test for environmental specifications when shielded cables are used for external wiring. We recommend the use of shielded cables. This kind of cable is available from ARBOR. Please contact your local supplier for ordering information.

### Warning

This is a class A product. In a domestic environment this product may cause radio interference in which case the user may be required to take adequate measures.

### FCC Class A

This device complies with Part 15 of the FCC Rules. Operation is subject to the following two conditions:

- (1) This device may not cause harmful interference, and
- (2) This device must accept any interference received, including interference that may cause undesired operation.

### NOTE:

This equipment has been tested and found to comply with the limits for a Class A digital device, pursuant to Part 15 of the FCC Rules. These limits are designed to provide reasonable protection against harmful interference when the equipment is operated in a commercial environment. This equipment generates, uses, and can radiate radio frequency energy and, if not installed and used in accordance with the instruction manual, may cause harmful interference to radio communications. Operation of this equipment in a residential area is likely to cause harmful interference in which case the user will be required to correct the interference at his own expense.

### RoHS

ARBOR Technology Corp. certifies that all components in its products are in compliance and conform to the European Union's Restriction of Use of Hazardous Substances in Electrical and Electronic Equipment (RoHS) Directive 2002/95/EC.

The above mentioned directive was published on 2/13/2003. The main purpose of the directive is to prohibit the use of lead, mercury, cadmium, hexavalent chromium, polybrominated biphenyls (PBB), and polybrominated diphenyl ethers (PBDE) in electrical and electronic products. Member states of the EU are to enforce by 7/1/2006.

ARBOR Technology Corp. hereby states that the listed products do not contain unintentional additions of lead, mercury, hex chrome, PBB or PBDB that exceed a maximum concentration value of 0.1% by weight or for cadmium exceed 0.01% by weight, per homogenous material. Homogenous material is defined as a substance or mixture of substances with uniform composition (such as solders, resins, plating, etc.). Lead-free solder is used for all terminations (Sn(96-96.5%), Ag(3.0-3.5%) and Cu(0.5%)).

### SVHC / REACH

To minimize the environmental impact and take more responsibility to the earth we live, Arbor hereby confirms all products comply with the restriction of SVHC (Substances of Very High Concern) in (EC) 1907/2006 (REACH --Registration, Evaluation, Authorization, and Restriction of Chemicals) regulated by the European Union.

All substances listed in SVHC < 0.1 % by weight (1000 ppm)

## **Important Safety Instructions**

Read these safety instructions carefully

1. Read all cautions and warnings on the equipment.
2. Place this equipment on a reliable surface when installing. Dropping it or letting it fall may cause damage
3. Make sure the correct voltage is connected to the equipment.
4. For pluggable equipment, the socket outlet should be near the equipment and should be easily accessible.
5. Keep this equipment away from humidity.
6. The openings on the enclosure are for air convection and protect the equipment from overheating. **DO NOT COVER THE OPENINGS.**
7. Position the power cord so that people cannot step on it. Do not place anything over the power cord.
8. Never pour any liquid into opening. This may cause fire or electrical shock.
9. Never open the equipment. For safety reasons, the equipment should be opened only by qualified service personnel.
10. If one of the following situations arises, get the equipment checked by service personnel:
  - a. The power cord or plug is damaged.
  - b. Liquid has penetrated into the equipment.
  - c. The equipment has been exposed to moisture.
  - d. The equipment does not work well, or you cannot get it to work according to the user's manual.
  - e. The equipment has been dropped or damaged.
  - f. The equipment has obvious signs of breakage.
11. Keep this User's Manual for later reference.

## **Warning**

The Box PC and its components contain very delicately Integrated Circuits (IC). To protect the Box PC and its components against damage caused by static electricity, you should always follow the precautions below when handling it:

1. Disconnect your Box PC from the power source when you want to work on the inside.
2. Use a grounded wrist strap when handling computer components.
3. Place components on a grounded antistatic pad or on the bag that came with the Box PC, whenever components are separated from the system.

## **Lithium Battery Replacement**

Incorrect replacement of the lithium battery may lead to a risk of explosion.

The lithium battery must be replaced with an identical battery or a battery type recommended by the manufacturer.

Do not throw lithium batteries into the trash can. It must be disposed of in accordance with local regulations concerning special waste.

## **Technical Support**

If you have any technical difficulties, please consult the user's manual first at:  
<http://www.arbor.com.tw>

Please do not hesitate to call or e-mail our customer service when you still cannot find out the answer.

<https://www.arbor-technology.com>

## **Warranty**

This product is warranted to be in good working order for a period of two year from the date of purchase. Should this product fail to be in good working order at any time during this period, we will, at our option, replace or repair it at no additional charge except as set forth in the following terms. This warranty does not apply to products damaged by misuse, modifications, accident or disaster.

Vendor assumes no liability for any damages, lost profits, lost savings or any other incidental or consequential damage resulting from the use, misuse of, or inability to use this product. Vendor will not be liable for any claim made by any other related party.

Vendors disclaim all other warranties, either expressed or implied, including but not limited to implied warranties of merchantability and fitness for a particular purpose, with respect to the hardware, the accompanying product's manual(s) and written materials, and any accompanying hardware. This limited warranty gives you specific legal rights.

Return authorization must be obtained from the vendor before returned merchandise will be accepted. Authorization can be obtained by calling or faxing the vendor and requesting a Return Merchandise Authorization (RMA) number. Returned goods should always be accompanied by a clear problem description.

---

This page is intentionally left blank.

---

# Chapter 1

## Introduction

## 1.1. The Computer

### Product Highlights

- Intel® Celeron® J6412 CPU Elkhart Lake (2.0 GHz/2.6GHz)
- Front panel support IP66
- Industrial-grade 10 points project capacitive touch screen
- Support Mini-PCIe/M.2 extension of multiple modules
- Support dual GbE LAN
- Support remote ON-OFF
- Grounding protection for product shell
- Support 1 x 2.5 inch HDD/SSD expansion
- Support standard VESA and panel mount



## 1.2. About this Manual

This manual is meant for the experienced users and integrators with hardware knowledge of personal computers. If you are not sure about the description in this manual, consult your vendor before further handling.

We recommend that you keep one copy of this manual for the quick reference for any necessary maintenance in the future. Thank you for choosing ARBOR products.



### 1.3. Specifications

System		
CPU	Intel® Celeron® J6412 CPU Elkhart Lake (2.0GHz/2.6GHz)	
Memory	1 x DDR4 2133/2400/3200MHz SO-DIMM slot, up to 32GB 4GB DDR4 SO-DIMM pre-installed*(CTOS)	
Graphics	Intel® UHD Graphics for 10th Gen Intel® Processors	
LAN Chipset	2 x Intel® I226-V GbE controllers (10/100/1000 Mbps)	
Watchdog Timer	Programmable 255 levels timer interval, from 1~255 sec/min	
Storage		
Device	1 x M.2 M Key 2242 Slot (SATA signal) 128GB M.2 SSD pre-installed*(CTOS)	
Audio		
Type	1 x Audio (Line-out & Mic-in 2 in 1) Realtek® ALC888S HD Audio codec	
Speaker	2 x 4Ω3W speaker	
LCD Display		
Size/Type	SP-151C-1J64	15.6" TFT LCD Panel
	SP-181C-1J64	18.5" TFT LCD Panel
	SP-181C-2J64	18.5" TFT LCD Panel
	SP-211C-1J64	21.5" TFT LCD Panel
	SP-150R-1J64	15.0" TFT LCD Panel
	SP-170R-1J64	17.0" TFT LCD Panel
Max. Resolution	SP-151C-1J64	1920(H) x 1080(V)
	SP-181C-1J64	1366(H) x 768(V)
	SP-181C-2J64	1920(H) x 1080(V)
	SP-211C-1J64	1920(H) x 1080(V)
	SP-150R-1J64	1024(H) x 768(V)
	SP-170R-1J64	1280(H) x 1024(V)
Ratio	SP-151C-1J64	16:9
	SP-181C-1J64	16:9
	SP-181C-2J64	16:9
	SP-211C-1J64	16:9
	SP-150R-1J64	4:3
	SP-170R-1J64	4:3
Luminance	SP-151C-1J64	450 cd/m <sup>2</sup>
	SP-181C-1J64	500 cd/m <sup>2</sup>
	SP-181C-2J64	350 cd/m <sup>2</sup>
	SP-211C-1J64	250 cd/m <sup>2</sup>
	SP-150R-1J64	300 cd/m <sup>2</sup>
	SP-170R-1J64	250 cd/m <sup>2</sup>

## Introduction

Contrast Ratio	SP-151C-1J64	800:1
	SP-181C-1J64	1000:1
	SP-181C-2J64	1000:1
	SP-211C-1J64	1000:1
	SP-150R-1J64	800:1
	SP-170R-1J64	1000:1
Backlight	LED Backlight	
Backlight Lifetime	SP-151C-1J64	50,000 Hrs
	SP-181C-1J64	50,000 Hrs
	SP-181C-2J64	30,000 Hrs
	SP-211C-1J64	30,000 Hrs
	SP-150R-1J64	30,000 Hrs
	SP-170R-1J64	50,000 Hrs
Touch Screen	SP-151C-1J64	P-cap Multi-Touch
	SP-181C-1J64	P-cap Multi-Touch
	SP-181C-2J64	P-cap Multi-Touch
	SP-211C-1J64	P-cap Multi-Touch
	SP-150R-1J64	5-wire resistive touch
	SP-170R-1J64	5-wire resistive touch
Touch	35,000,000 times	
View Angle	SP-151C-1J64	CR ≥ 10; $\theta_x$ 178°(H)/ $\theta_y$ 178°(V)
	SP-181C-1J64	89°/89°/89°/89° (Typ.)(CR≥10)
	SP-181C-2J64	CR > 10, 85°(T)/85°(B)/85°(L)/85°(R)
	SP-211C-1J64	CR > 10, 89°(H)/89°(V)
	SP-150R-1J64	80°/80°/80°/80°
	SP-170R-1J64	CR ≥ 10, 170°(H)/160°(V); CR ≥ 5, 178°(H)/170°(V)
<b>Power System</b>		
Power Input	DC 12~36V 1 x Power Connector (2P Phoenix)	
<b>Qualification</b>		
Certification	CE, FCC	
<b>Internal I/O Expansion</b>		
Expansion Bus	1 x Mini-PCIe slot (PCIe/ USB2.0 signal supported) 1 x M.2 2230 slot (PCIe/ USB2.0 signal supported) 1 x M.2 2242 slot (SATA signal supported) 1 x SIM socket for 3G/4G 1 x 8bit GPIO 3.3V(jumper)/5V(default) power 1 x RS232-COM4 2 x RS232(RX/TX)-COM5/6 2 x USB2.0--For Touch 1 x SATA3.0/Power 5V for HDD	
<b>Mechanical</b>		
Mounting Type	Panel Mount, Wall and VESA-mount (75 x 75mm)	
Chassis	Aluminum for front Panel and heat-sink, SECC for Rear Cover	

Dimension (W x H x D)	SP-151C-1J64	395 x 245.5 x 66mm
	SP-181C-1J64	470.8 x 317.4 x 73mm
	SP-181C-2J64	470.5 x 295.6 x 67mm
	SP-211C-1J64	528.2 x 321.9 x 66mm
	SP-150R-1J64	351.6 x 275.6 x 68.4mm
	SP-170R-1J64	392.4 x 327.7 x 66mm
Weight (Net)	SP-151C-1J64	4.2 kg
	SP-181C-1J64	6.8 kg
	SP-181C-2J64	6.2 kg
	SP-211C-1J64	6.9 kg
	SP-150R-1J64	4.5 kg
	SP-170R-1J64	5.2 kg
Ingress Protection	Front panel IP66	
<b>Environmental</b>		
Operating Temp.	SP-151C-1J64	-10°C ~ 60°C
	SP-181C-1J64	-10°C ~ 60°C
	SP-181C-2J64	-10°C ~ 60°C
	SP-211C-1J64	-10°C ~ 50°C
	SP-150R-1J64	-10°C ~ 60°C
	SP-170R-1J64	-10°C ~ 50°C
Storage Temp.	-40°C ~ 70°C	
Operating Humidity	5 ~ 95% (non-condensing)	
Random Vibration	5~500Hz, 2Grms operation	
Sine Vibration	5~500Hz, 2G Non-operation	
Shock	10g 11ms operation, 30g 11ms Non-operation	
<b>OS Support</b>		
Windows 10/11, Linux(Ubuntu)		

## 1.4. Inside the Package

Upon opening the package, carefully inspect the contents. If any of the items is missing or appears damaged, contact your local dealer or distributor. The package should contain the following items:



1 x SP-XXXC/R-1J64/2J64  
(SP-151C-1J64 / SP-181C-1J64 / SP-181C-2J64 /  
SP-211C-1J64 / SP-150R-1J64 / SP-170R-1J64)  
\*Product appearance varies by model.

1 x **Accessory Box** that contains the following items:

- 1 x 4pin Power Connector (Phoenix)
- 1 x 2pin SW connector
- Panel Hook (15/15.6 inch x 4pcs,  
17/18.5/21.5 inch x 8pcs)
- 4 x VESA-mount screws
- 4 x HDD screws
- 1 x Storage Thermal pad
- 1 x SSD Thermal Pad

---

# Chapter 2

## Getting Started

## 2.1. Dimensions

### SP-151C-1J64

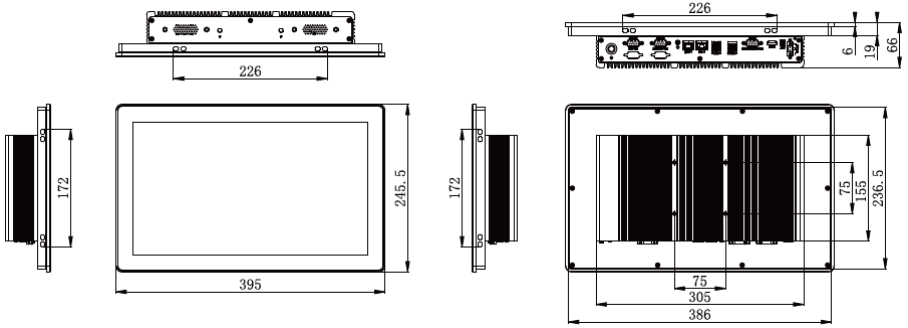

Unit: mm

### SP-181C-1J64

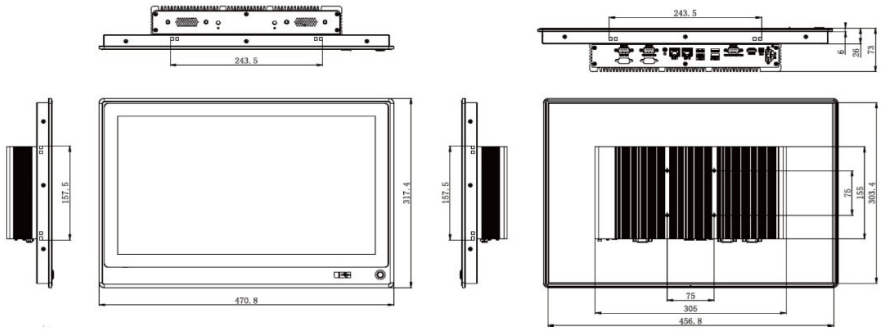

Unit: mm

### SP-181C-2J64

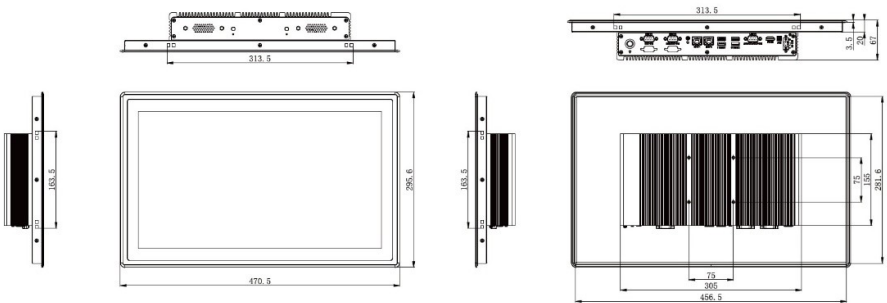

Unit: mm

**SP-211C-1J64**

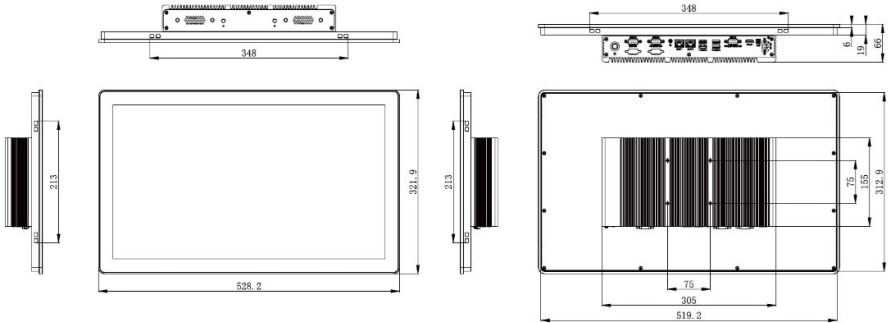

Unit: mm

**SP-150R-1J64**

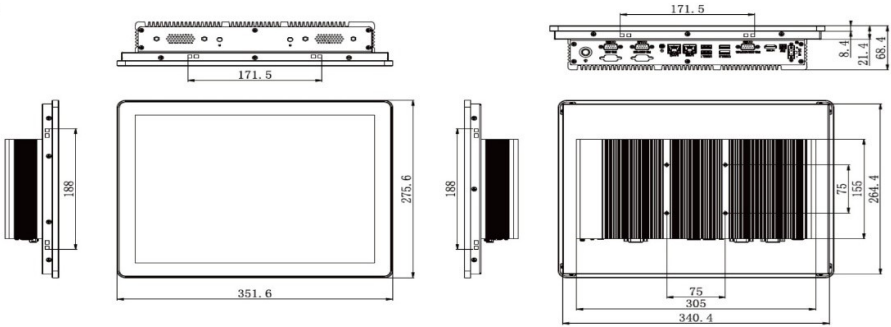

Unit: mm

**SP-170R-1J64**

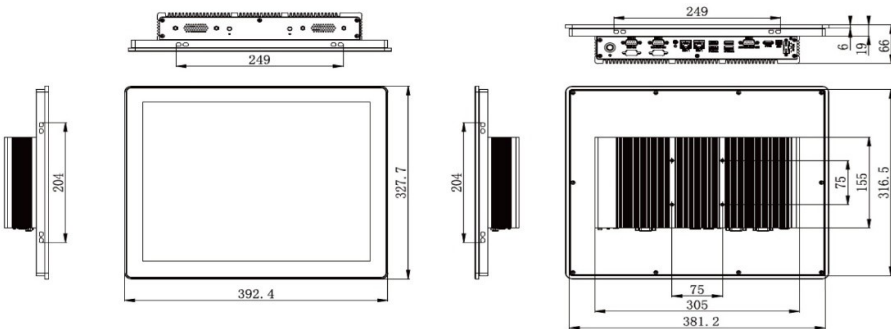

Unit: mm

## 2.2. Tour the Computer

Take a look around the computer and find the external controls and connectors.

### 2.2.1. Front View

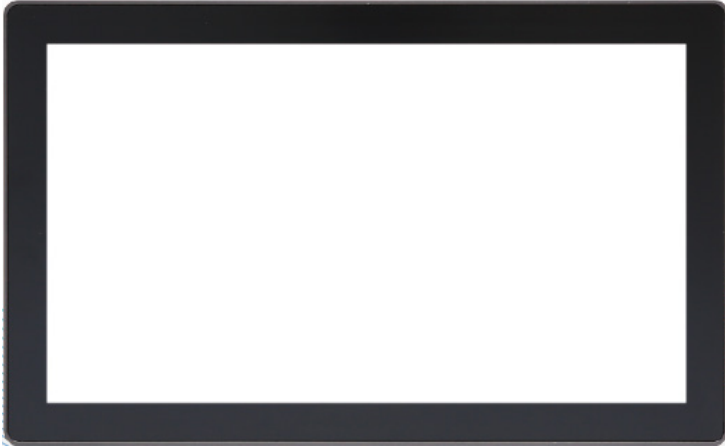

\*Product appearance varies by model.

### 2.2.2. Bottom I/O View

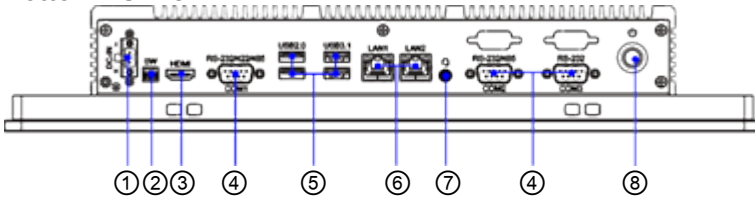

No.	Description
①	DC-in Power Connector
②	Remote On/Off Control
③	HDMI port
④	COM Port, RS-232/422/485 selectable*
⑤	4 x Type-A USB 3.1/2.0 ports*
⑥	2 x RJ-45 LAN ports

⑦	Audio Port
⑧	Power On/Off Button

Note: COM1 is in RS232/422/485 mode, COM2 is in RS232(default)/485(Jumper) mode, and COM3 is in RS232 mode.

Note: Two of the red USB port are USB 3.1 port and the rest of black ports are USB 2.0 port.

### 2.2.3. I/O Definition

#### ① DC-IN

**Function:** Power input terminal block  
**Connector Type:** 1x2-pin Terminal block  
**Pin Assignment:**

Pin	Desc.
1	+12~36V DC
2	GND

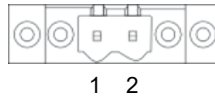

#### ② Remote On/Off Control 2-pin terminal block

**Function:** 2-pin terminal block for remote control  
**Connector Type:** 1x2-pin Terminal block  
**Pin Assignment:**

Pin	Desc.
1	PWRBTN#
2	GND

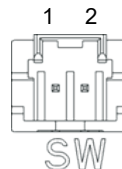

#### ③ HDMI

**Function:** HDMI display output  
**Pin Assignment:** The pin assignments conform to the industry standard.

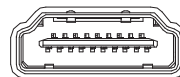

#### ④ COM Ports

**Function:** RS-232/422/485 Selectable Serial Port

**Connector Type:** External 9-pin D-sub male connector

**Pin Assignment:**

	Pin	Desc.	Pin	Desc.
<b>RS-232</b>	1	DCD	6	DSR
	2	RXD	7	RTS
	3	TXD	8	CTS
	4	DTR	9	RI
	5	GND		
<b>RS-422</b>	1	TX-		
	2	TX+		
	3	RX+		
	4	RX-		
	5	GND		
<b>RS-485</b>	1	DATA-		
	2	DATA+		

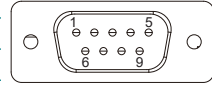

SP-xxxC/R-xJ64 supports 3 serial ports, COM1 supports RS232/422/485 mode, COM2 supports RS232/485 mode and COM3 supports RS232 mode. By default, COM1 & COM2 are in RS232 mode, COM1 can be switched to RS422/485 mode through BIOS setting (refer to P34), and COM2 can be switched to RS485 mode through jump cap setting, please refer to P21.

## ⑤ USB Port

- Function:** USB 3.1/2.0 ports  
**Connector Type:** USB 3.1/2.0 type A connectors  
**Pin Assignment:** The pin assignments conform to the industry standard.



USB Version	Theoretically Speed	USB Code Name	Maximum Voltage/Current
USB 2.0	480Mbps	High-Speed	5V/500mA
USB 3.1	10Gbps	Super-High-Speed	5V/900mA

\*The product supports 4 USB ports. 2 for USB3.1 ports and 2 for USB2.0 ports.

## ⑥ LAN Port

- Function:** RJ-45 port for Giga LAN  
**Connector Type:** 2 x RJ-45 connectors that support 10/100/1000/2500Mbps fast Ethernet  
**Pin Assignment:** The pin assignments conform to the industry standard.

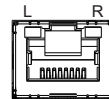

Both ports use the Intel i226V LAN chip, which can support Wake-on-LAN function. 2 indicator LAN lights on the ports, which are defined as follows:

Light	Description	Status
L	Networking Status	Off: Not working Green: Working
R	Networking Speed Status	Off: 10Mbps Green: 100Mbps Orange: 1000/2500Mbps

## ⑦ Audio Port

- Function:** For external microphone, headphones or speakers.  
**Connector Type:** 3.5mm audio port interface  
**Pin Assignment:** Support a 2-in-1 audio I/O interface with a 3.5mm hole diameter for external microphones, headphones, or speakers on a 4-segment iPhone version devices.

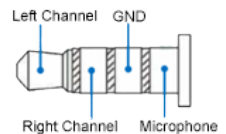

## ⑧ Power On/Off Button

**Function**                  Power Button

Description	Status	
Power LED Status	<ul style="list-style-type: none"><li>▶ Off: Power off or system is in hibernate mode</li><li>▶ Green LED Permanently: System is working</li><li>▶ Green LED Blinking: S3 hibernate mode.</li></ul>	

---

## ⑨ Antenna Hole

There are 2 antenna reserved holes on the top of the product to facilitate users to install the antenna of the wireless module.

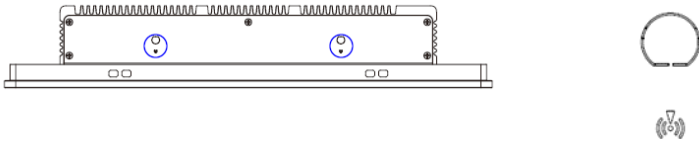

---

# Chapter 3

## Engine of the Computer

### 3.1. Board Layout

Main Board (SP-XXXC/R-1J64/2J64)

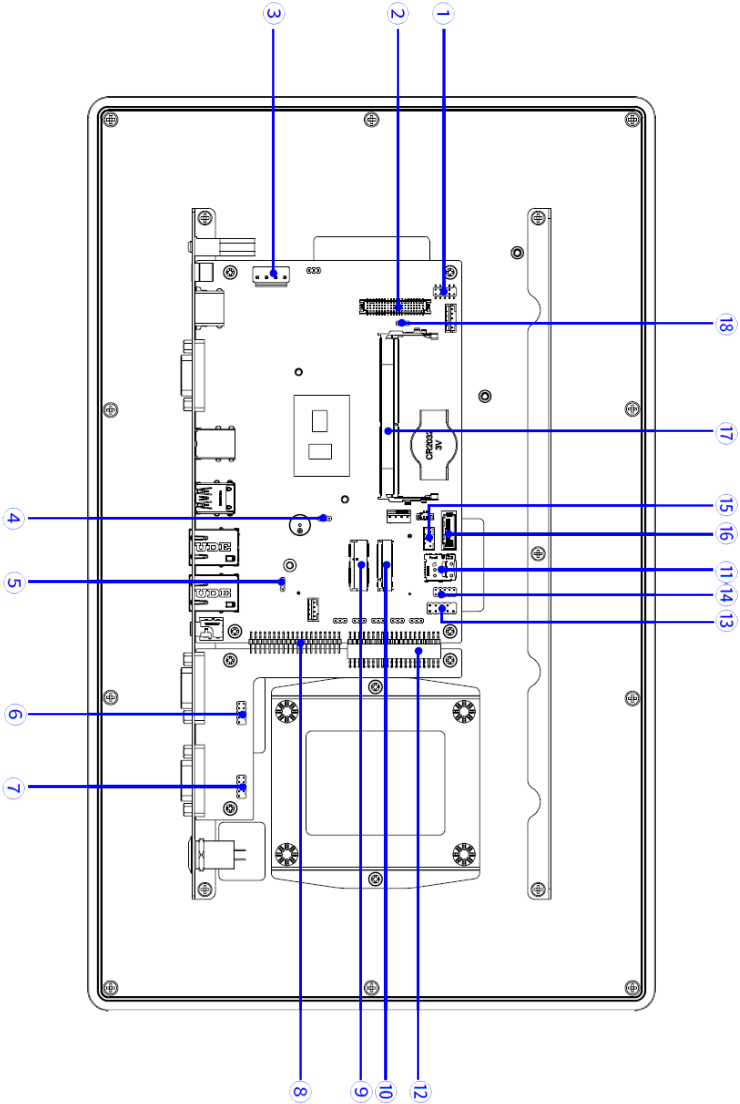

<b>Label</b>	<b>Description</b>
(1) JUSB1	USB Connector
(2) LVDS1	LCD Connector
(3) PWR1	Power Connector
(4) JCMOS1	CMOS Jumper
(5) JP1	AT/ATX Selection
(6) JCOM4	Serial Connector
(7) JCOM5_6	Serial Connector
(8) J2	LAN Module Connector
(9) M2_WIFI1	M.2 2230 Wi-Fi Slot
(10) M2_SSD1	M.2 SSD Socket
(11) JSIM1	SIM Card Socket
(12) J1	External I/O Card Connector
(13) FP1	FP Connector
(14) GPIO1	GPIO1 Connector
(15) SATAPWR1	SATA Power Connector
(16) SATA1	Serial ATA Connector
(17) DIMM1	DDR4 SO-DIMM Socket
(18) LVDS_PWR1	LVDS Power Setting

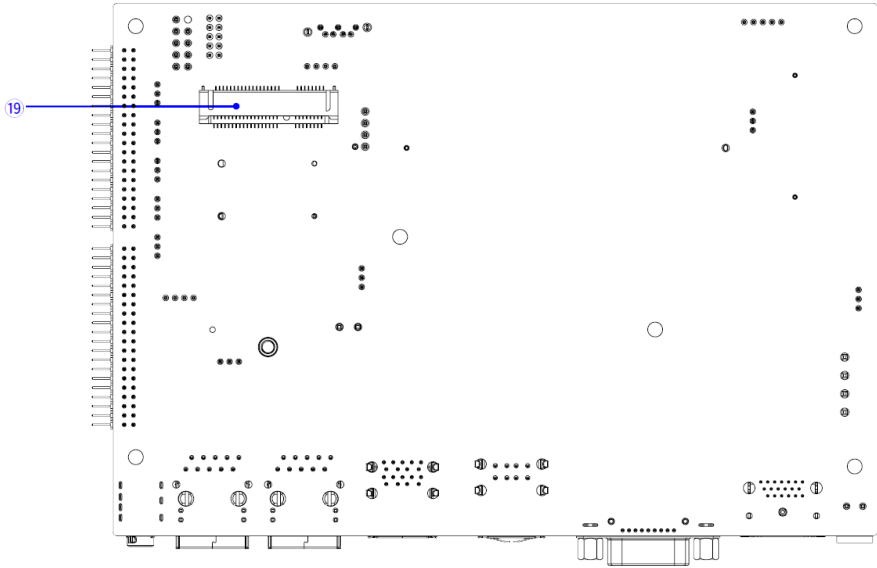

<b>Label</b>	<b>Description</b>
(19) MINI_PCIE1	Mini-PCIe Socket

## 3.2. Connectors & Jumpers

### (1) JUSB1

**Function:** JUSB1 is USB connector on the device

**Connector Type:** 2x5 pin header

**Pin Assignment:**

	Pin	Desc.	Pin	Desc.
USB2.0	1	5V	2	5V
	3	USB6N	4	USB7N
	5	USB6P	6	USB7P
	7	GND	8	GND
	9	NC	10	X

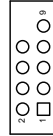



Note: JUSB1 is the built-in USB connector on the board, which can lead to two USB2.0 ports via USB cables.

### (4) JCMOS1

**Function:** Clears/keeps CMOS

**Jumper Type:** 2.00 mm pitch 1x2-pin header

**Setting:**



Pin	Description	
Short	Keeps CMOS (default)	
Open	Clears CMOS	

### (5) JP1

**Function:** AT/ATX Power selection

**Jumper Type:** Onboard pitch 1x3-pin header

**Setting:**

Pin	Description	
Short 1-2	ATX Mode	
Short 2-3	AT Mode	

### (6) JCOM4

**Function:** RS232 DB9 connector

**Connector Type:** 2x5 pin header

**Pin Assignment:**

	Pin	Desc.	Pin	Desc.
<b>RS232</b>	1	DCD	2	DSR
	3	RXD	4	RTS
	5	TXD	6	CTS
	7	DTR	8	RI
	9	GND	10	NC

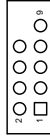

Note: JCOM4 is the built-in serial interface connector of the board. It can lead out serial port 2 through the serial cable, and serial port 4 only supports RS232. Wake On Ring function is the default setting.

### (7) JCOM5\_6

**Function:** RS232 DB9 connector

**Connector Type:** 2x5 pin header

**Pin Assignment:**

	Pin	Desc.	Pin	Desc.
<b>RS232</b>	1	DCD	2	DSR
	3	RXD	4	RTS
	5	TXD	6	CTS
	7	DTR	8	RI
	9	GND	10	NC

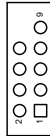

Note: JCOM5\_6 is the built-in serial interface connector of the board. It can lead out serial port 2 through the serial cable, and serial port 4 only supports RS232. Wake On Ring function is not supported.

### (13) FP Connector

**Function:** FP Connector

**Connector Type:** 2x5 pin header

**Pin Assignment:**

Pin	Desc.	Pin	Desc.
1	SATA_LED+	2	PWR_LED+
3	SATA_LED-	4	PWR_LED-
5	GND	6	GND
7	HWRSR_N	8	PWR_SW_N
9	NC		



Note: JFP1 is a front panel connector that provides switches and signals for Power on/off, reboot, hard disk light, power light, etc.

### (14) GPIO1

**Function:** GPIO Connector

**Connector Type:** 2x5-pin header

**Pin Assignment:**

Pin	Description	Pin	Description
1	GPIO1	2	GPIO2
3	GPIO3	4	GPIO4
5	GPIO5	6	GPIO6
7	GPIO7	8	GPIO8
9	JGPWR*	10	GND

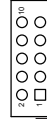



Note: The default setting is 5V. Instead, it can be changed to 3.3V by using the jump cap GPIO\_PWR1.

### (18) LVDS\_PWR1

**Function:** Switching between 3.3V and 5V LVDS power voltage.

**Jumper Type:** Onboard pitch 1x3-pin header



**Setting:**

Pin	Description	
<b>Short 1-2</b>	Support 5V for monitor	
<b>Short 2-3</b>	Support 3.3V for monitor (Default)	

### COM2\_J1 ~ COM2\_J4

**Jumper Type:** Onboard pitch 1x3-pin header

**Setting:**

Pin	Description	
<b>Short 1-2</b>	RS232 mode (Default)	
<b>Short 2-3</b>	RS485 mode	

Note: COM2\_J1~COM2\_J4: All 4 jumpers are 1-2 in short-for RS232 mode. 4 jumpers are 2-3 shorting for RS485 mode.

---

This page is intentionally left blank.

---

# Chapter 4

## Installation & Maintenance

## 4.1. Disassembling and Assembling the Computer

This section will guide you to install the Wi-Fi module, memory and SSD. If you don't need to install the Wi-Fi module, skip the Wi-Fi related sections.

The installation procedures for SP-151C-1J64, SP-181C-1J64, SP-181C-2J64, SP-211C-1J64, SP-150R-1J64 and SP-170R-1J64 are similar. This section will use the SP-151C-1J64 to illustrate the procedures.

### 4.1.1. Disassembling the Computer

To use onboard jumpers/connectors or to install/remove internal components, you will need to open the computer to access the inside of the computer. Follow through the guide below to disassembly the computer.

1. Position the computer with the rear side facing up and remove screws securing the chassis as shown below .

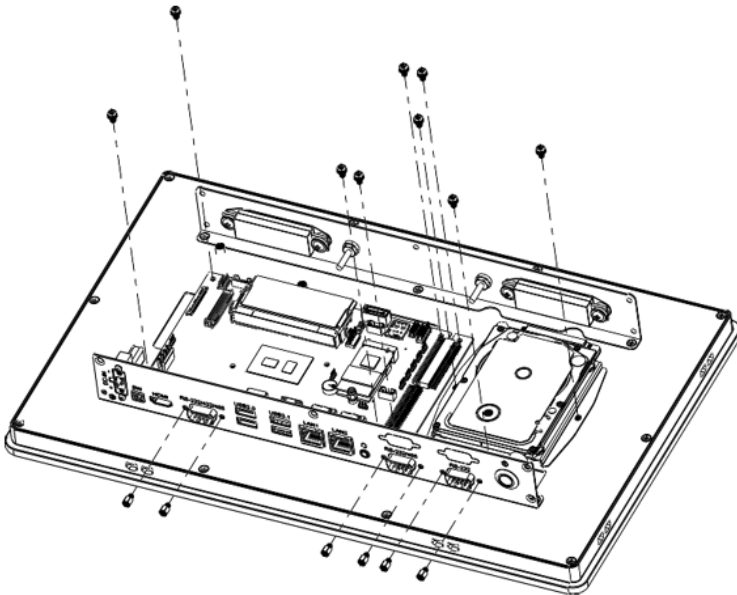

2. You are ready to access the components on the main board and make required configurations and connections.

### 4.1.2. Assembling the Computer

After completing the required hardware installation and jumpers settings, assemble the computer by performing the proceeding steps in reverse order.

## 4.2. Install M.2 2242 SSD, M.2 2230 & Memory Stick Module

To install the M.2 2242 SSD and M.2 2230, you have to remove the rear cover to access the SSD slot first. Please refer to to [4.1.1. Disassembling the Computer on page 24.](#)

### Install Memory

Install the SO-DIMM DDR4 memory stick, note that when installing the memory stick. Align the notch on the memory module with the key in the module socket. Slide the module into place. Once the memory module is fully inserted into the socket, press down on the top edge of the device to latch it into place.

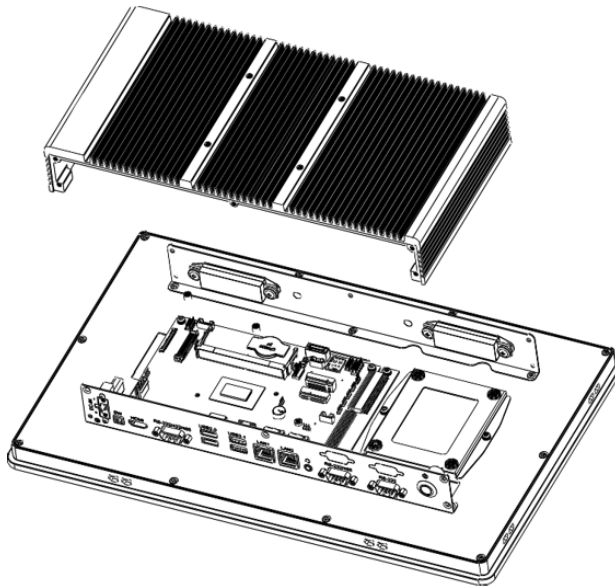

## Install M.2 2242 SSD & M.2 2230 Module

Remove the screw at the M.2 position and install the M.2 2230 module/M2242 SSD into the M.2 slot. When installing the M.2 2242 SSD/M.2 2230 module, align the notch with the slot, insert it tightly, and fasten it with M3\*3 screw from the accessory box.

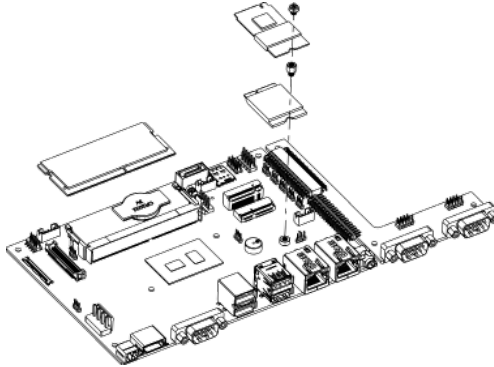

After installing M.2 device, please place the thermal pad on the M.2 module. Align thermal pad with the heat-generating area of the component and ensure that it covers the entire surface area that requires thermal contact. Once it is in position, apply gentle pressure to the component to ensure good contact and compression between the pad and the surface.

Recover rear cover and fasten the screws show as below.

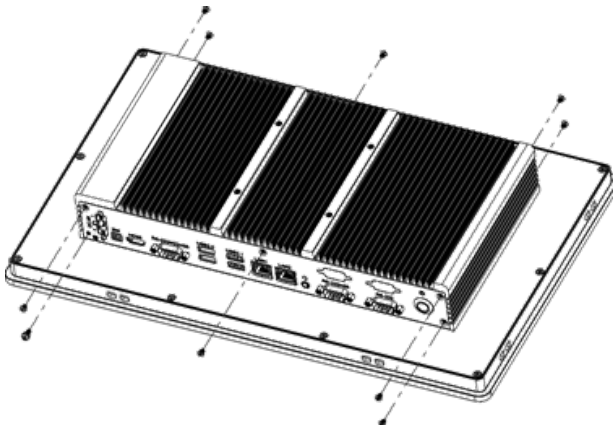

### 4.3. Install the Wi-Fi Module

1. To install the Mini-PCIe module, you have to remove the rear cover to access the computer then remove all the screws on the computer board. Please refer to [4.1.1. Disassembling the Computer on page 24](#). Insert the 3G/4G module into the slot, and then fasten the flat head M2\*3 screw on the module.
2. Recover computer board and rear cover then fasten the screws.

### 4.4. Mounting Method

There are different ways to mount the device, including panel mounting, VESA mounting, and cabinet mounting.

#### 4.4.1. Panel Mounting

1. Position the product into the mounting holes.
2. Retrieve the four mounting clips from the accessory box and snap them into the side mounting holes.
3. Secure the clips, tighten the screws firmly.

#### 4.4.2. VESA Mounting

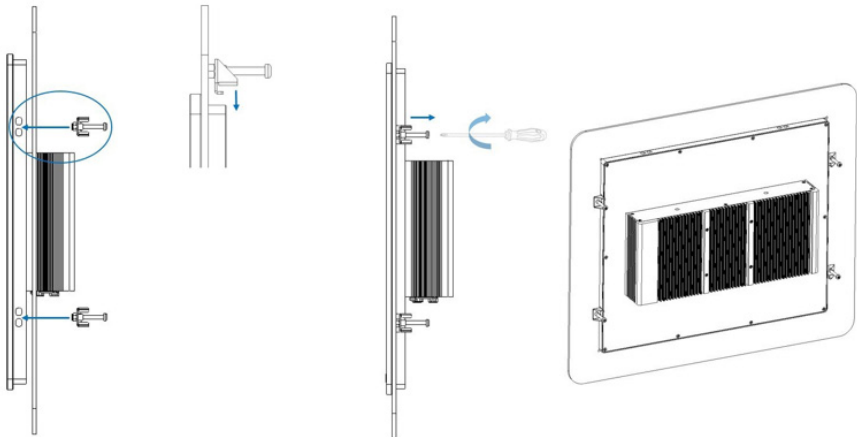

Attach the VESA bracket to the product's 75 x 75mm VESA hole by four screws.

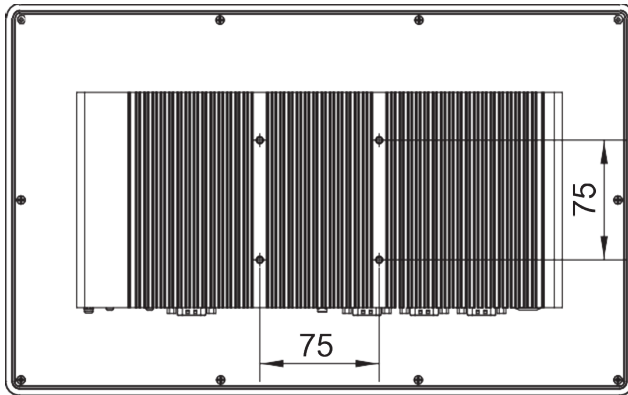

1. Install the product into the cabinet according to chapter 5.1 panel Mounting;
2. Connect the cabinet to ground and make sure that there is a common ground inside the cabinet;
3. Connect the power supply ground inside the cabinet to cabinet ground;
4. Ensure that the product connect to the same ground with cabinet.

---

# Chapter 5

## BIOS

## BIOS

---

The BIOS Setup utility for the SP series are featured by American Megatrends Inc to configure the system settings stored in the system's BIOS ROM. The BIOS is activated once the computer powers on. When the computer is off, the battery on the main board supplies power to BIOS RAM.

To enter the BIOS Setup utility, keep hitting the "Delete" key upon powering on the computer.

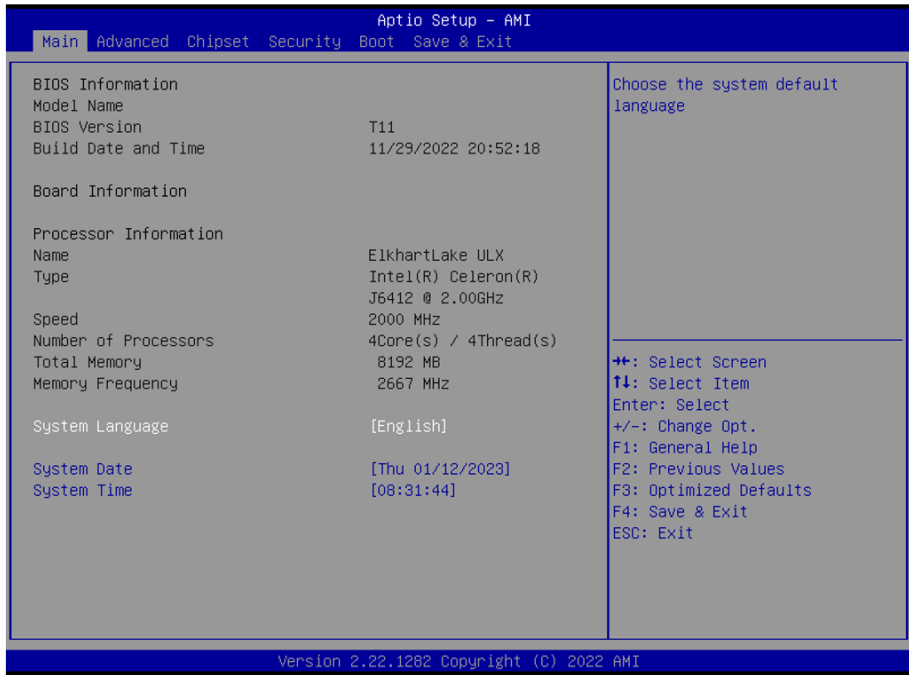

Note: Actual model name and board information varies according to your model.

## Key Commands

The BIOS Setup utility relies on a keyboard to receive user's instructions. Hit the following keys to navigate within the utility and use the utility.

Keystroke	Function	
<b>F7</b>	Enter the boot up sequence menu	<b>After System Open</b>
<b>DEL</b>	Enter the BIOS menu	
<b>Ctrl + Alt + DEL</b>	Restart the system	
← →	Moves left/right between the top menus.	<b>In BIOS</b>
↓ ↑	Moves up/down between highlight items.	
<b>Enter</b>	Selects an highlighted item/field.	
<b>Page Up / +</b>	Increases current value to the next higher value or switches between available options.	
<b>Page Down / -</b>	Decreases current value to the next lower value or switches between available options.	
<b>F1</b>	General Help	
<b>F2</b>	Previous Values	
<b>F3</b>	Load defaults	
<b>F4</b>	Save the Settings and Quit the BIOS	
<b>Esc</b>	<ul style="list-style-type: none"> <li>▶ On the top menus: Use <b>Esc</b> to quit the utility without saving changes to CMOS. (The screen will prompt a message asking you to select <b>OK</b> or <b>Cancel</b> to exit discarding changes.</li> <li>▶ On the submenus: Use <b>Esc</b> to quit current screen and return to the top menu.</li> </ul>	

Note: Pay attention to the "WARNING" that shows at the left pane onscreen when making any change to the BIOS settings.

This BIOS Setup utility is updated from time to time to improve system performance and hence the screenshots hereinafter may not fully comply with what you actually have onscreen.

## 5.1. Main - Sets system Time & Date.

The **Main** menu features the settings of **System Date** and **System Time** and displays some BIOS info.

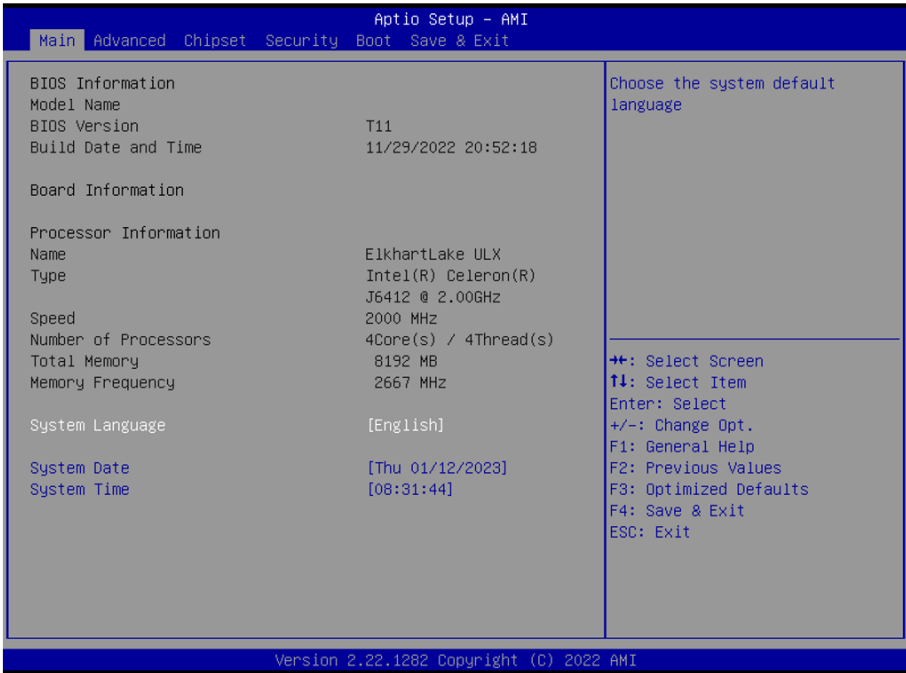

Note: Actual model name and board information varies according to your model.

Setting	Description
<b>System Date</b>	Sets system date.
<b>System Time</b>	Sets system time.

## 5.2. Advanced

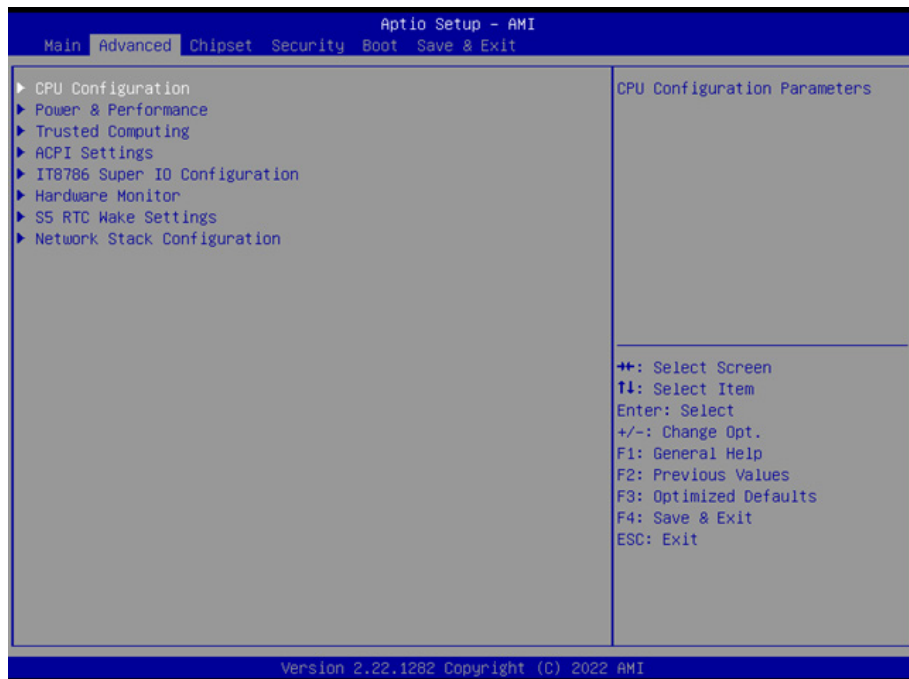

### 5.2.1. COM Mode Setting

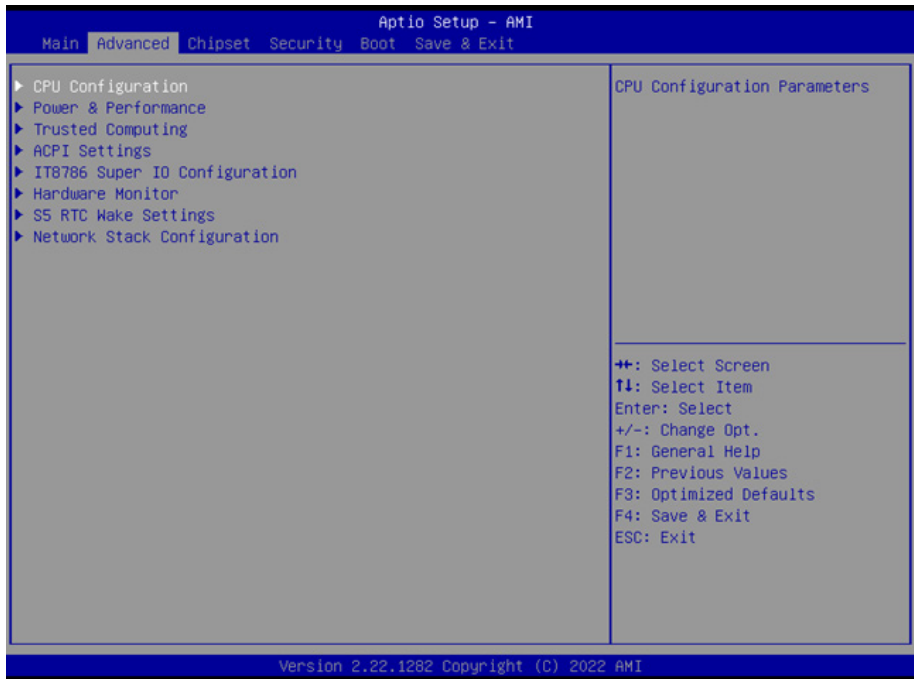

Enter Advanced menu, select "IT8786 Super IO Configuration" -> "Serial Port 1 Configuration" -> "COM Mode Select". You can select RS232, RS422, RS485 for the COM1 Mode Setting.

## 5.2.2. Wake System with Fixed time

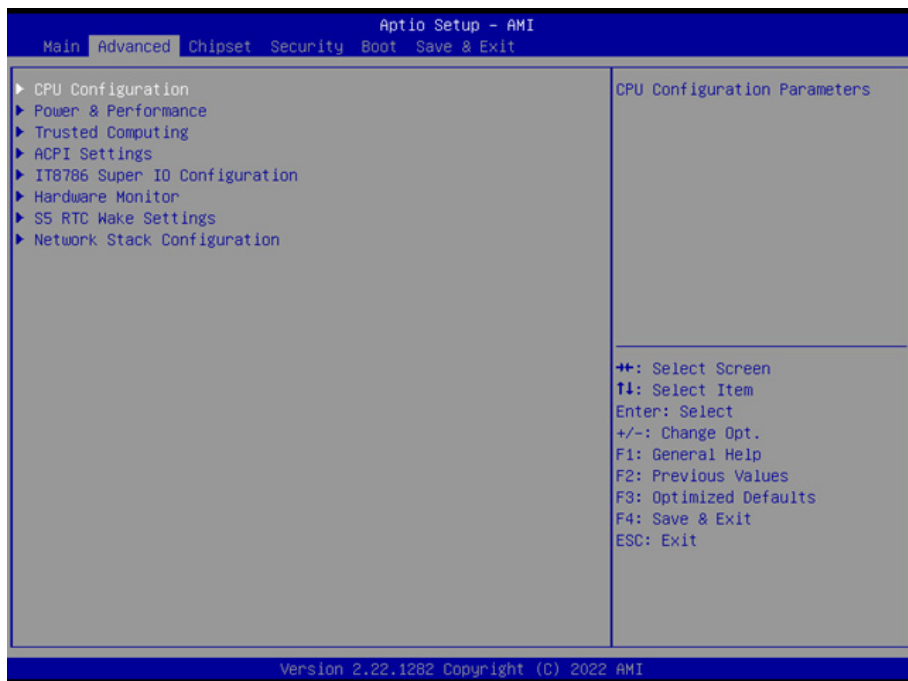

Enter Advanced menu, select "**S5 RTC Wake Settings**" -> "**Wake system with Fixed time**". Then select enabled you can select fixed date/time to wake the system.

Setting	Description
<b>Wake System from S5</b>	<p><b>Enable</b> or <b>Disable</b> (default) system wake on alarm event.</p> <p>► Options available are:</p> <p><b>Disabled</b> (default):</p> <p><b>Fixed Time:</b> System will wake on the hr::min::sec specified.</p>

### 5.3. BIOS Chipset Menu



Enter Chipset menu, select "**PCH-IO Configuration**"-> "**State After G3**" in order, then select **S0 State/S5 State** to set the power on mode. S0 State is AT mode; it will power on automatically after connecting to the power supply. S5 State is ATX mode; you need to press the power button to turn on the power after connecting to the power supply.

Note: After setting, press F4 to save and exit, the system will take effect upon rebooting your system.

### 5.3.1. BIOS Chipset Menu



Enter Chipset Menu, select the "PCH-IO Configuration"-> "USB Power in S4/S5" in turn, you can set the USB power in shutdown/hibernation state according to the actual application needs, select Enabled or Disabled to turn it on or off, after the setting is completed. After setting, press F4 to save and exit, the system will take effect upon rebooting your system.

Note: If the setting is "Disabled", it will not support USB wake-up in S4 (hibernation) and S5 (power off) states.

## 5.4. Security

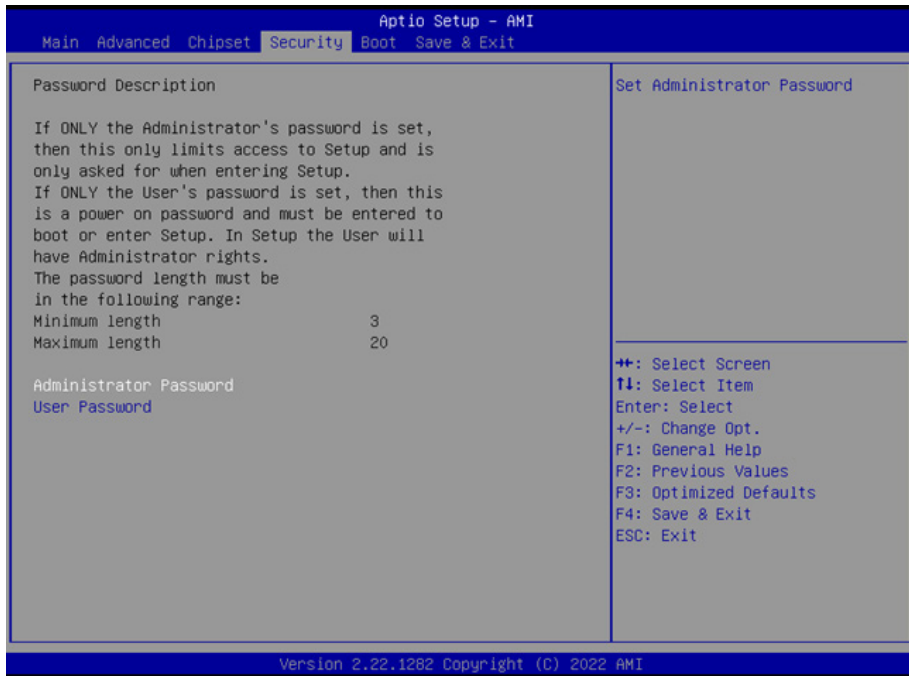

Setting	Description
<b>Administrator Password</b>	<p>To set up an administrator password:</p> <ol style="list-style-type: none"> <li>1. Select <b>Administrator Password</b>.</li> <li>2. A <b>Create New Password</b> dialog then pops up onscreen.</li> <li>3. Enter your desired password that is no less than 3 characters and no more than 20 characters.</li> <li>4. Hit [Enter] key to submit.</li> </ol>

## 5.5. Boot

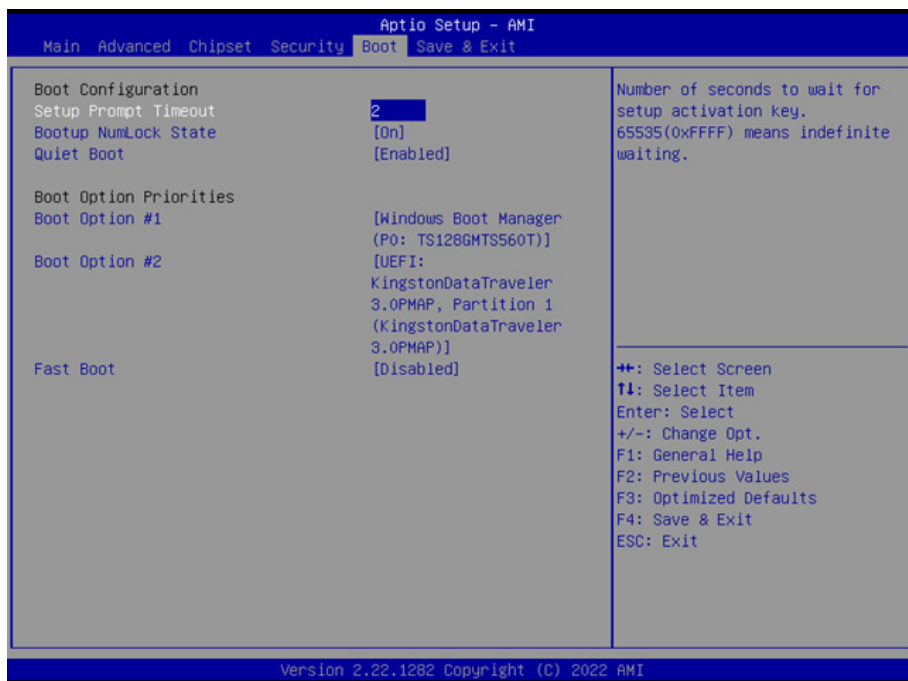

Setting	Description
<b>Quiet Boot</b>	Sets whether to display the POST (Power-on Self Tests) messages or the system manufacturer's full screen logo during booting. Select Quiet Boot <ul style="list-style-type: none"> <li>▶ Enabled: Logo will be displayed at boot.</li> <li>▶ Disabled: Show the self-test screen at boot, without logo.</li> </ul>
<b>Boot Option Priority</b>	Set the system boot priorities. After setting press F4 to save and exit, the Changes will take effect upon reboot..

Note: After setting, press F4 to save and exit, the system will take effect upon rebooting your system.

## 5.6. Save & Exit

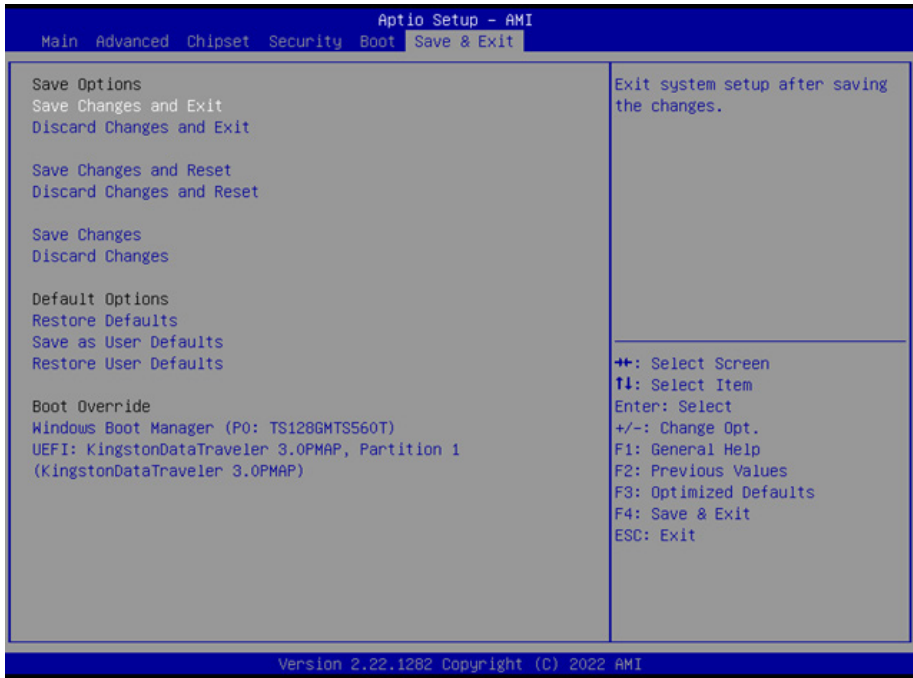

The Save & Exit menu shows you how to exit the BIOS Setup Utility. When you have completed the setup, you must save and exit for the changes to take effect.